

FK - MNP 系列接頭組件

管徑4,6,8,10,12,5/32",1/4",5/16"等
NDSQG系列

FKPIC6-M5 迷你直直接頭

公制規格

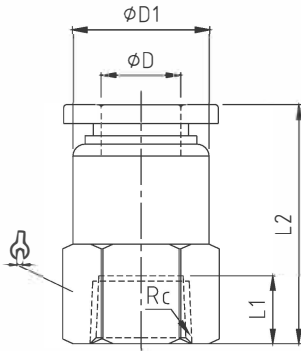

管徑 ØD	牙徑 Rc (PT)	型式	L1	L2	ØD	R	ØD1	↻
Ø4	M5	NDSQG 4 - M5	5.5	21	4	M5	10	10
	1/8"	NDSQG 4 - 01	8.5	24	4	Rc1/8	10	14
	1/4"	NDSQG 4 - 02	11	26.5	4	Rc1/4	10	17
Ø6	M5	NDSQG 6 - M5	5.5	21.5	6	M5	12	12
	1/8"	NDSQG 6 - 01	8.5	24.5	6	Rc1/8	12	14
	1/4"	NDSQG 6 - 02	11	27	6	Rc1/4	12	17
	3/8"	NDSQG 6 - 03	12	28	6	Rc3/8	12	21
Ø8	1/8"	NDSQG 8 - 01	8.5	26	8	Rc1/8	14	14
	1/4"	NDSQG 8 - 02	11	28.5	8	Rc1/4	14	17
	3/8"	NDSQG 8 - 03	12	29.5	8	Rc3/8	14	21
Ø10	1/8"	NDSQG 10 - 01	8.5	29.5	10	Rc1/8	17	17
	1/4"	NDSQG 10 - 02	11	32.7	10	Rc1/4	17	17
	3/8"	NDSQG 10 - 03	12	33	10	Rc3/8	17	21
	1/2"	NDSQG 10 - 04	14	35.7	10	Rc1/2	17	24
Ø12	1/4"	NDSQG 12 - 02	11	33.5	12	Rc1/4	20	21
	3/8"	NDSQG 12 - 03	12	34.5	12	Rc3/8	20	21
	1/2"	NDSQG 12 - 04	14	36.5	12	Rc1/2	20	24

英制規格

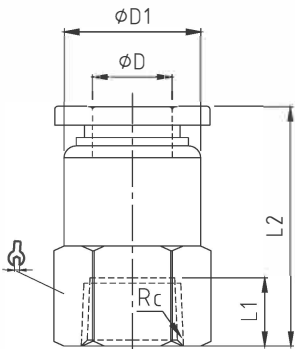

管徑 ØD	牙徑 NPT	型式	L1	L2	ØD	R	ØD1	↻
5/32"	1/8"	NDSQG 5/32 - 01	8.5	24	5/32	NPT1/8	10	9/16
	1/4"	NDSQG 5/32 - 02	11	26.5	5/32	NPT1/4	10	11/16
1/4"	1/8"	NDSQG 1/4 - 01	8.5	24.5	1/4	NPT1/8	12	9/16
	1/4"	NDSQG 1/4 - 02	11	27	1/4	NPT1/4	12	11/16
	3/8"	NDSQG 1/4 - 03	12	28	1/4	NPT3/8	12	7/8
	1/2"	NDSQG 1/4 - 04	14	30	1/4	NPT1/2	12	1/1
5/16"	1/8"	NDSQG 5/16 - 01	8.5	26	5/16	NPT1/8	14	9/16
	1/4"	NDSQG 5/16 - 02	11	28.5	5/16	NPT1/4	14	11/16
	3/8"	NDSQG 5/16 - 03	12	29.5	5/16	NPT3/8	14	7/8
	1/2"	NDSQG 5/16 - 04	14	31.5	5/16	NPT1/2	14	1/1
3/8"	1/8"	NDSQG 3/8 - 01	8.5	29.5	3/8	NPT1/8	17	11/16
	1/4"	NDSQG 3/8 - 02	11	32.7	3/8	NPT1/4	17	11/16
	3/8"	NDSQG 3/8 - 03	12	33	3/8	NPT3/8	17	7/8
	1/2"	NDSQG 3/8 - 04	14	35.7	3/8	NPT1/2	17	1/1
1/2"	1/8"	NDSQG 1/2 - 01	8.5	31	1/2	NPT1/8	20	7/8
	1/4"	NDSQG 1/2 - 02	11	33.5	1/2	NPT1/4	20	7/8
	3/8"	NDSQG 1/2 - 03	12	34.5	1/2	NPT3/8	20	7/8
	1/2"	NDSQG 1/2 - 04	14	36.5	1/2	NPT1/2	20	1/1

接頭、輔助元件

標準型接頭類

迷你型接頭類

柱塞類

插管式接頭類

逆止接頭類

調速接頭類

手動開關類

氣管類

消音器類

FKPIC 系列接頭組件

管徑4,6,8,10,12,5/32",1/4",5/16"等
NDSQG系列

FKPIC6-M5 迷你直直接頭

公制規格

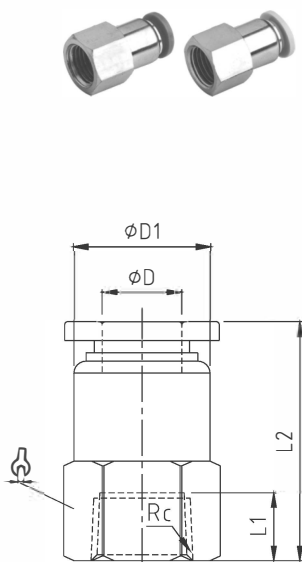

管徑 ØD	牙徑 Rc (PT)	型式	L1	L2	ØD	R	ØD1	↻
Ø4	M5	NDSQG 4 - M5	5.5	21	4	M5	10	10
	1/8"	NDSQG 4 - 01	8.5	24	4	Rc1/8	10	14
	1/4"	NDSQG 4 - 02	11	26.5	4	Rc1/4	10	17
Ø6	M5	NDSQG 6 - M5	5.5	21.5	6	M5	12	12
	1/8"	NDSQG 6 - 01	8.5	24.5	6	Rc1/8	12	14
	1/4"	NDSQG 6 - 02	11	27	6	Rc1/4	12	17
	3/8"	NDSQG 6 - 03	12	28	6	Rc3/8	12	21
Ø8	1/8"	NDSQG 8 - 01	8.5	26	8	Rc1/8	14	14
	1/4"	NDSQG 8 - 02	11	28.5	8	Rc1/4	14	17
	3/8"	NDSQG 8 - 03	12	29.5	8	Rc3/8	14	21
Ø10	1/8"	NDSQG 10 - 01	8.5	29.5	10	Rc1/8	17	17
	1/4"	NDSQG 10 - 02	11	32.7	10	Rc1/4	17	17
	3/8"	NDSQG 10 - 03	12	33	10	Rc3/8	17	21
	1/2"	NDSQG 10 - 04	14	35.7	10	Rc1/2	17	24
Ø12	1/4"	NDSQG 12 - 02	11	33.5	12	Rc1/4	20	21
	3/8"	NDSQG 12 - 03	12	34.5	12	Rc3/8	20	21
	1/2"	NDSQG 12 - 04	14	36.5	12	Rc1/2	20	24

英制規格

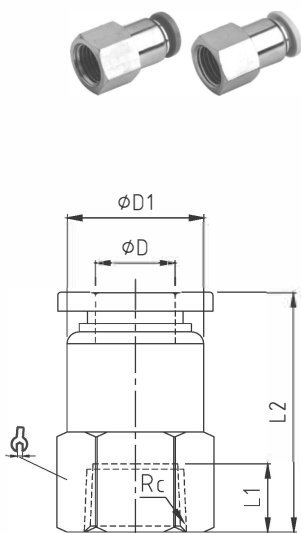

管徑 ØD	牙徑 NPT	型式	L1	L2	ØD	R	ØD1	↻
5/32"	1/8"	NDSQG 5/32 - 01	8.5	24	5/32	NPT1/8	10	9/16
	1/4"	NDSQG 5/32 - 02	11	26.5	5/32	NPT1/4	10	11/16
1/4"	1/8"	NDSQG 1/4 - 01	8.5	24.5	1/4	NPT1/8	12	9/16
	1/4"	NDSQG 1/4 - 02	11	27	1/4	NPT1/4	12	11/16
	3/8"	NDSQG 1/4 - 03	12	28	1/4	NPT3/8	12	7/8
	1/2"	NDSQG 1/4 - 04	14	30	1/4	NPT1/2	12	1/1
5/16"	1/8"	NDSQG 5/16 - 01	8.5	26	5/16	NPT1/8	14	9/16
	1/4"	NDSQG 5/16 - 02	11	28.5	5/16	NPT1/4	14	11/16
	3/8"	NDSQG 5/16 - 03	12	29.5	5/16	NPT3/8	14	7/8
	1/2"	NDSQG 5/16 - 04	14	31.5	5/16	NPT1/2	14	1/1
3/8"	1/8"	NDSQG 3/8 - 01	8.5	29.5	3/8	NPT1/8	17	11/16
	1/4"	NDSQG 3/8 - 02	11	32.7	3/8	NPT1/4	17	11/16
	3/8"	NDSQG 3/8 - 03	12	33	3/8	NPT3/8	17	7/8
	1/2"	NDSQG 3/8 - 04	14	35.7	3/8	NPT1/2	17	1/1
1/2"	1/8"	NDSQG 1/2 - 01	8.5	31	1/2	NPT1/8	20	7/8
	1/4"	NDSQG 1/2 - 02	11	33.5	1/2	NPT1/4	20	7/8
	3/8"	NDSQG 1/2 - 03	12	34.5	1/2	NPT3/8	20	7/8
	1/2"	NDSQG 1/2 - 04	14	36.5	1/2	NPT1/2	20	1/1

接頭、輔助元件

標準型接頭類

迷你型接頭類

柱塞類

插管式接頭類

逆止接頭類

調速接頭類

手動開關類

氣管類

消音器類

NDSAQC 系列接頭組件

管徑4,6,8,10,12,5/32",1/4",5/16"等
NDSQG系列

◎NDSAQC6-1直直接頭

公制規格

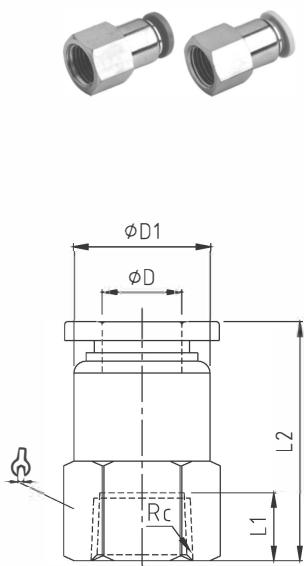

管徑 ØD	牙徑 Rc (PT)	型式	L1	L2	ØD	R	ØD1	↻
Ø4	M5	NDSQG 4 - M5	5.5	21	4	M5	10	10
	1/8"	NDSQG 4 - 01	8.5	24	4	Rc1/8	10	14
	1/4"	NDSQG 4 - 02	11	26.5	4	Rc1/4	10	17
Ø6	M5	NDSQG 6 - M5	5.5	21.5	6	M5	12	12
	1/8"	NDSQG 6 - 01	8.5	24.5	6	Rc1/8	12	14
	1/4"	NDSQG 6 - 02	11	27	6	Rc1/4	12	17
	3/8"	NDSQG 6 - 03	12	28	6	Rc3/8	12	21
Ø8	1/8"	NDSQG 8 - 01	8.5	26	8	Rc1/8	14	14
	1/4"	NDSQG 8 - 02	11	28.5	8	Rc1/4	14	17
	3/8"	NDSQG 8 - 03	12	29.5	8	Rc3/8	14	21
Ø10	1/8"	NDSQG 10 - 01	8.5	29.5	10	Rc1/8	17	17
	1/4"	NDSQG 10 - 02	11	32.7	10	Rc1/4	17	17
	3/8"	NDSQG 10 - 03	12	33	10	Rc3/8	17	21
	1/2"	NDSQG 10 - 04	14	35.7	10	Rc1/2	17	24
Ø12	1/4"	NDSQG 12 - 02	11	33.5	12	Rc1/4	20	21
	3/8"	NDSQG 12 - 03	12	34.5	12	Rc3/8	20	21
	1/2"	NDSQG 12 - 04	14	36.5	12	Rc1/2	20	24

英制規格

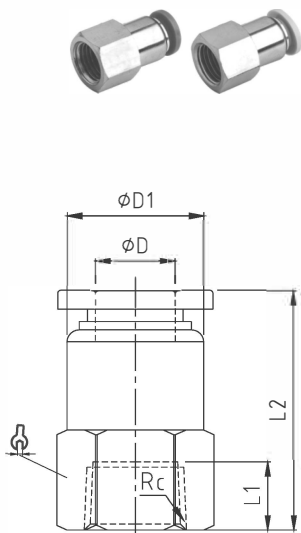

管徑 ØD	牙徑 NPT	型式	L1	L2	ØD	R	ØD1	↻
5/32"	1/8"	NDSQG 5/32 - 01	8.5	24	5/32	NPT1/8	10	9/16
	1/4"	NDSQG 5/32 - 02	11	26.5	5/32	NPT1/4	10	11/16
1/4"	1/8"	NDSQG 1/4 - 01	8.5	24.5	1/4	NPT1/8	12	9/16
	1/4"	NDSQG 1/4 - 02	11	27	1/4	NPT1/4	12	11/16
	3/8"	NDSQG 1/4 - 03	12	28	1/4	NPT3/8	12	7/8
	1/2"	NDSQG 1/4 - 04	14	30	1/4	NPT1/2	12	1/1
5/16"	1/8"	NDSQG 5/16 - 01	8.5	26	5/16	NPT1/8	14	9/16
	1/4"	NDSQG 5/16 - 02	11	28.5	5/16	NPT1/4	14	11/16
	3/8"	NDSQG 5/16 - 03	12	29.5	5/16	NPT3/8	14	7/8
	1/2"	NDSQG 5/16 - 04	14	31.5	5/16	NPT1/2	14	1/1
3/8"	1/8"	NDSQG 3/8 - 01	8.5	29.5	3/8	NPT1/8	17	11/16
	1/4"	NDSQG 3/8 - 02	11	32.7	3/8	NPT1/4	17	11/16
	3/8"	NDSQG 3/8 - 03	12	33	3/8	NPT3/8	17	7/8
	1/2"	NDSQG 3/8 - 04	14	35.7	3/8	NPT1/2	17	1/1
1/2"	1/8"	NDSQG 1/2 - 01	8.5	31	1/2	NPT1/8	20	7/8
	1/4"	NDSQG 1/2 - 02	11	33.5	1/2	NPT1/4	20	7/8
	3/8"	NDSQG 1/2 - 03	12	34.5	1/2	NPT3/8	20	7/8
	1/2"	NDSQG 1/2 - 04	14	36.5	1/2	NPT1/2	20	1/1

接頭、輔助元件

標準型接頭類

迷你型接頭類

柱塞類

插管式接頭類

逆止接頭類

調速接頭類

手動開關類

氣管類

消音器類

NDSAQC 系列接頭組件

管徑4,6,8,10,12,5/32",1/4",5/16"等
NDSQG系列

◎NDSAQC6-2直直接頭

公制規格

管徑 ØD	牙徑 Rc (PT)	型式	L1	L2	ØD	R	ØD1	↻
Ø4	M5	NDSQG 4 - M5	5.5	21	4	M5	10	10
	1/8"	NDSQG 4 - 01	8.5	24	4	Rc1/8	10	14
	1/4"	NDSQG 4 - 02	11	26.5	4	Rc1/4	10	17
Ø6	M5	NDSQG 6 - M5	5.5	21.5	6	M5	12	12
	1/8"	NDSQG 6 - 01	8.5	24.5	6	Rc1/8	12	14
	1/4"	NDSQG 6 - 02	11	27	6	Rc1/4	12	17
	3/8"	NDSQG 6 - 03	12	28	6	Rc3/8	12	21
Ø8	1/8"	NDSQG 8 - 01	8.5	26	8	Rc1/8	14	14
	1/4"	NDSQG 8 - 02	11	28.5	8	Rc1/4	14	17
	3/8"	NDSQG 8 - 03	12	29.5	8	Rc3/8	14	21
Ø10	1/8"	NDSQG 10 - 01	8.5	29.5	10	Rc1/8	17	17
	1/4"	NDSQG 10 - 02	11	32.7	10	Rc1/4	17	17
	3/8"	NDSQG 10 - 03	12	33	10	Rc3/8	17	21
	1/2"	NDSQG 10 - 04	14	35.7	10	Rc1/2	17	24
Ø12	1/4"	NDSQG 12 - 02	11	33.5	12	Rc1/4	20	21
	3/8"	NDSQG 12 - 03	12	34.5	12	Rc3/8	20	21
	1/2"	NDSQG 12 - 04	14	36.5	12	Rc1/2	20	24

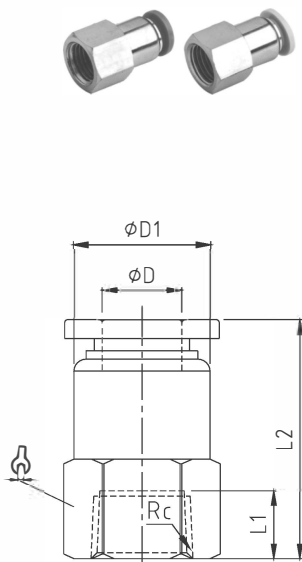

英制規格

管徑 ØD	牙徑 NPT	型式	L1	L2	ØD	R	ØD1	↻
5/32"	1/8"	NDSQG 5/32 - 01	8.5	24	5/32	NPT1/8	10	9/16
	1/4"	NDSQG 5/32 - 02	11	26.5	5/32	NPT1/4	10	11/16
1/4"	1/8"	NDSQG 1/4 - 01	8.5	24.5	1/4	NPT1/8	12	9/16
	1/4"	NDSQG 1/4 - 02	11	27	1/4	NPT1/4	12	11/16
	3/8"	NDSQG 1/4 - 03	12	28	1/4	NPT3/8	12	7/8
	1/2"	NDSQG 1/4 - 04	14	30	1/4	NPT1/2	12	1/1
5/16"	1/8"	NDSQG 5/16 - 01	8.5	26	5/16	NPT1/8	14	9/16
	1/4"	NDSQG 5/16 - 02	11	28.5	5/16	NPT1/4	14	11/16
	3/8"	NDSQG 5/16 - 03	12	29.5	5/16	NPT3/8	14	7/8
	1/2"	NDSQG 5/16 - 04	14	31.5	5/16	NPT1/2	14	1/1
3/8"	1/8"	NDSQG 3/8 - 01	8.5	29.5	3/8	NPT1/8	17	11/16
	1/4"	NDSQG 3/8 - 02	11	32.7	3/8	NPT1/4	17	11/16
	3/8"	NDSQG 3/8 - 03	12	33	3/8	NPT3/8	17	7/8
	1/2"	NDSQG 3/8 - 04	14	35.7	3/8	NPT1/2	17	1/1
1/2"	1/8"	NDSQG 1/2 - 01	8.5	31	1/2	NPT1/8	20	7/8
	1/4"	NDSQG 1/2 - 02	11	33.5	1/2	NPT1/4	20	7/8
	3/8"	NDSQG 1/2 - 03	12	34.5	1/2	NPT3/8	20	7/8
	1/2"	NDSQG 1/2 - 04	14	36.5	1/2	NPT1/2	20	1/1

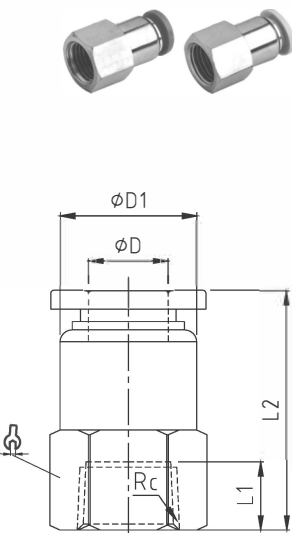

接頭、輔助元件

標準型接頭類

迷你型接頭類

柱塞類

插管式接頭類

逆止接頭類

調速接頭類

手動開關類

氣管類

消音器類

NDSAQC 系列接頭組件

管徑4,6,8,10,12,5/32",1/4",5/16"等
NDSQG系列

◎NDSAQC6-MC5直立接頭

公制規格

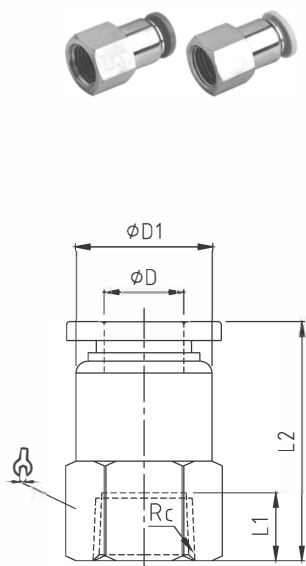

管徑 ØD	牙徑 Rc (PT)	型式	L1	L2	ØD	R	ØD1	↻
Ø4	M5	NDSQG 4 - M5	5.5	21	4	M5	10	10
	1/8"	NDSQG 4 - 01	8.5	24	4	Rc1/8	10	14
	1/4"	NDSQG 4 - 02	11	26.5	4	Rc1/4	10	17
Ø6	M5	NDSQG 6 - M5	5.5	21.5	6	M5	12	12
	1/8"	NDSQG 6 - 01	8.5	24.5	6	Rc1/8	12	14
	1/4"	NDSQG 6 - 02	11	27	6	Rc1/4	12	17
	3/8"	NDSQG 6 - 03	12	28	6	Rc3/8	12	21
Ø8	1/8"	NDSQG 8 - 01	8.5	26	8	Rc1/8	14	14
	1/4"	NDSQG 8 - 02	11	28.5	8	Rc1/4	14	17
	3/8"	NDSQG 8 - 03	12	29.5	8	Rc3/8	14	21
Ø10	1/8"	NDSQG 10 - 01	8.5	29.5	10	Rc1/8	17	17
	1/4"	NDSQG 10 - 02	11	32.7	10	Rc1/4	17	17
	3/8"	NDSQG 10 - 03	12	33	10	Rc3/8	17	21
	1/2"	NDSQG 10 - 04	14	35.7	10	Rc1/2	17	24
Ø12	1/4"	NDSQG 12 - 02	11	33.5	12	Rc1/4	20	21
	3/8"	NDSQG 12 - 03	12	34.5	12	Rc3/8	20	21
	1/2"	NDSQG 12 - 04	14	36.5	12	Rc1/2	20	24

英制規格

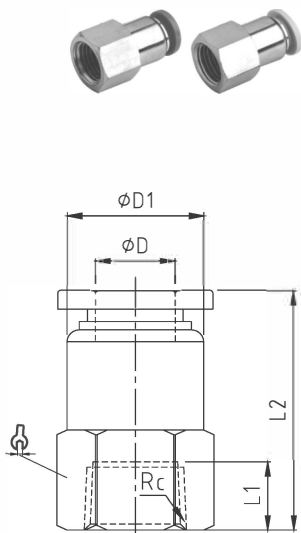

管徑 ØD	牙徑 NPT	型式	L1	L2	ØD	R	ØD1	↻
5/32"	1/8"	NDSQG 5/32 - 01	8.5	24	5/32	NPT1/8	10	9/16
	1/4"	NDSQG 5/32 - 02	11	26.5	5/32	NPT1/4	10	11/16
1/4"	1/8"	NDSQG 1/4 - 01	8.5	24.5	1/4	NPT1/8	12	9/16
	1/4"	NDSQG 1/4 - 02	11	27	1/4	NPT1/4	12	11/16
	3/8"	NDSQG 1/4 - 03	12	28	1/4	NPT3/8	12	7/8
	1/2"	NDSQG 1/4 - 04	14	30	1/4	NPT1/2	12	1/1
5/16"	1/8"	NDSQG 5/16 - 01	8.5	26	5/16	NPT1/8	14	9/16
	1/4"	NDSQG 5/16 - 02	11	28.5	5/16	NPT1/4	14	11/16
	3/8"	NDSQG 5/16 - 03	12	29.5	5/16	NPT3/8	14	7/8
	1/2"	NDSQG 5/16 - 04	14	31.5	5/16	NPT1/2	14	1/1
3/8"	1/8"	NDSQG 3/8 - 01	8.5	29.5	3/8	NPT1/8	17	11/16
	1/4"	NDSQG 3/8 - 02	11	32.7	3/8	NPT1/4	17	11/16
	3/8"	NDSQG 3/8 - 03	12	33	3/8	NPT3/8	17	7/8
	1/2"	NDSQG 3/8 - 04	14	35.7	3/8	NPT1/2	17	1/1
1/2"	1/8"	NDSQG 1/2 - 01	8.5	31	1/2	NPT1/8	20	7/8
	1/4"	NDSQG 1/2 - 02	11	33.5	1/2	NPT1/4	20	7/8
	3/8"	NDSQG 1/2 - 03	12	34.5	1/2	NPT3/8	20	7/8
	1/2"	NDSQG 1/2 - 04	14	36.5	1/2	NPT1/2	20	1/1

接頭、輔助元件

標準型接頭類

迷你型接頭類

柱塞類

插管式接頭類

逆止接頭類

調速接頭類

手動開關類

氣管類

消音器類

NDSAQC 系列接頭組件

管徑4,6,8,10,12,5/32",1/4",5/16"等
NDSQG系列

◎NDSAQC8-1直直接頭

公制規格

管徑 ØD	牙徑 Rc (PT)	型式	L1	L2	ØD	R	ØD1	↻
Ø4	M5	NDSQG 4 - M5	5.5	21	4	M5	10	10
	1/8"	NDSQG 4 - 01	8.5	24	4	Rc1/8	10	14
	1/4"	NDSQG 4 - 02	11	26.5	4	Rc1/4	10	17
Ø6	M5	NDSQG 6 - M5	5.5	21.5	6	M5	12	12
	1/8"	NDSQG 6 - 01	8.5	24.5	6	Rc1/8	12	14
	1/4"	NDSQG 6 - 02	11	27	6	Rc1/4	12	17
	3/8"	NDSQG 6 - 03	12	28	6	Rc3/8	12	21
Ø8	1/8"	NDSQG 8 - 01	8.5	26	8	Rc1/8	14	14
	1/4"	NDSQG 8 - 02	11	28.5	8	Rc1/4	14	17
	3/8"	NDSQG 8 - 03	12	29.5	8	Rc3/8	14	21
Ø10	1/8"	NDSQG 10 - 01	8.5	29.5	10	Rc1/8	17	17
	1/4"	NDSQG 10 - 02	11	32.7	10	Rc1/4	17	17
	3/8"	NDSQG 10 - 03	12	33	10	Rc3/8	17	21
	1/2"	NDSQG 10 - 04	14	35.7	10	Rc1/2	17	24
Ø12	1/4"	NDSQG 12 - 02	11	33.5	12	Rc1/4	20	21
	3/8"	NDSQG 12 - 03	12	34.5	12	Rc3/8	20	21
	1/2"	NDSQG 12 - 04	14	36.5	12	Rc1/2	20	24

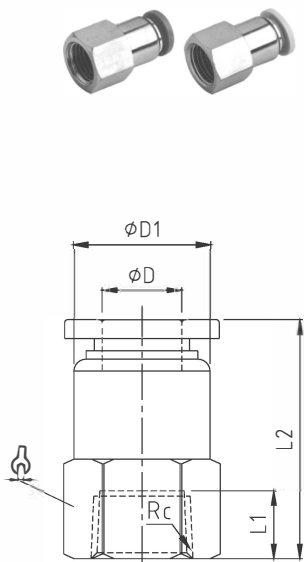

英制規格

管徑 ØD	牙徑 NPT	型式	L1	L2	ØD	R	ØD1	↻
5/32"	1/8"	NDSQG 5/32 - 01	8.5	24	5/32	NPT1/8	10	9/16
	1/4"	NDSQG 5/32 - 02	11	26.5	5/32	NPT1/4	10	11/16
1/4"	1/8"	NDSQG 1/4 - 01	8.5	24.5	1/4	NPT1/8	12	9/16
	1/4"	NDSQG 1/4 - 02	11	27	1/4	NPT1/4	12	11/16
	3/8"	NDSQG 1/4 - 03	12	28	1/4	NPT3/8	12	7/8
	1/2"	NDSQG 1/4 - 04	14	30	1/4	NPT1/2	12	1/1
5/16"	1/8"	NDSQG 5/16 - 01	8.5	26	5/16	NPT1/8	14	9/16
	1/4"	NDSQG 5/16 - 02	11	28.5	5/16	NPT1/4	14	11/16
	3/8"	NDSQG 5/16 - 03	12	29.5	5/16	NPT3/8	14	7/8
	1/2"	NDSQG 5/16 - 04	14	31.5	5/16	NPT1/2	14	1/1
3/8"	1/8"	NDSQG 3/8 - 01	8.5	29.5	3/8	NPT1/8	17	11/16
	1/4"	NDSQG 3/8 - 02	11	32.7	3/8	NPT1/4	17	11/16
	3/8"	NDSQG 3/8 - 03	12	33	3/8	NPT3/8	17	7/8
	1/2"	NDSQG 3/8 - 04	14	35.7	3/8	NPT1/2	17	1/1
1/2"	1/8"	NDSQG 1/2 - 01	8.5	31	1/2	NPT1/8	20	7/8
	1/4"	NDSQG 1/2 - 02	11	33.5	1/2	NPT1/4	20	7/8
	3/8"	NDSQG 1/2 - 03	12	34.5	1/2	NPT3/8	20	7/8
	1/2"	NDSQG 1/2 - 04	14	36.5	1/2	NPT1/2	20	1/1

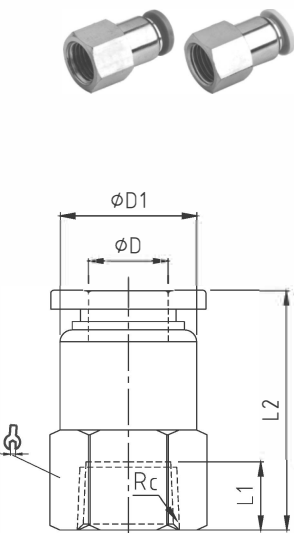

接頭、輔助元件

標準型接頭類

迷你型接頭類

柱塞類

插管式接頭類

逆止接頭類

調速接頭類

手動開關類

氣管類

消音器類

NDSAQC 系列接頭組件

管徑4,6,8,10,12,5/32",1/4",5/16"等
NDSQG系列

◎NDSAQC8-2直直接頭

公制規格

管徑 ØD	牙徑 Rc (PT)	型式	L1	L2	ØD	R	ØD1	↻
Ø4	M5	NDSQG 4 - M5	5.5	21	4	M5	10	10
	1/8"	NDSQG 4 - 01	8.5	24	4	Rc1/8	10	14
	1/4"	NDSQG 4 - 02	11	26.5	4	Rc1/4	10	17
Ø6	M5	NDSQG 6 - M5	5.5	21.5	6	M5	12	12
	1/8"	NDSQG 6 - 01	8.5	24.5	6	Rc1/8	12	14
	1/4"	NDSQG 6 - 02	11	27	6	Rc1/4	12	17
	3/8"	NDSQG 6 - 03	12	28	6	Rc3/8	12	21
Ø8	1/8"	NDSQG 8 - 01	8.5	26	8	Rc1/8	14	14
	1/4"	NDSQG 8 - 02	11	28.5	8	Rc1/4	14	17
	3/8"	NDSQG 8 - 03	12	29.5	8	Rc3/8	14	21
Ø10	1/8"	NDSQG 10 - 01	8.5	29.5	10	Rc1/8	17	17
	1/4"	NDSQG 10 - 02	11	32.7	10	Rc1/4	17	17
	3/8"	NDSQG 10 - 03	12	33	10	Rc3/8	17	21
	1/2"	NDSQG 10 - 04	14	35.7	10	Rc1/2	17	24
Ø12	1/4"	NDSQG 12 - 02	11	33.5	12	Rc1/4	20	21
	3/8"	NDSQG 12 - 03	12	34.5	12	Rc3/8	20	21
	1/2"	NDSQG 12 - 04	14	36.5	12	Rc1/2	20	24

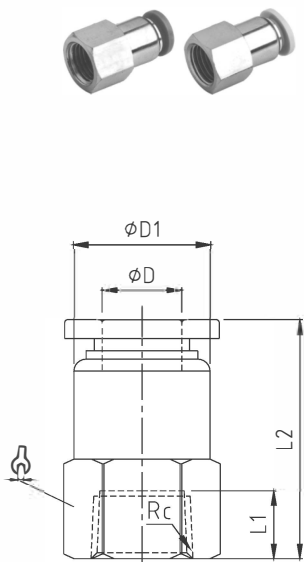

英制規格

管徑 ØD	牙徑 NPT	型式	L1	L2	ØD	R	ØD1	↻
5/32"	1/8"	NDSQG 5/32 - 01	8.5	24	5/32	NPT1/8	10	9/16
	1/4"	NDSQG 5/32 - 02	11	26.5	5/32	NPT1/4	10	11/16
1/4"	1/8"	NDSQG 1/4 - 01	8.5	24.5	1/4	NPT1/8	12	9/16
	1/4"	NDSQG 1/4 - 02	11	27	1/4	NPT1/4	12	11/16
	3/8"	NDSQG 1/4 - 03	12	28	1/4	NPT3/8	12	7/8
	1/2"	NDSQG 1/4 - 04	14	30	1/4	NPT1/2	12	1/1
5/16"	1/8"	NDSQG 5/16 - 01	8.5	26	5/16	NPT1/8	14	9/16
	1/4"	NDSQG 5/16 - 02	11	28.5	5/16	NPT1/4	14	11/16
	3/8"	NDSQG 5/16 - 03	12	29.5	5/16	NPT3/8	14	7/8
	1/2"	NDSQG 5/16 - 04	14	31.5	5/16	NPT1/2	14	1/1
3/8"	1/8"	NDSQG 3/8 - 01	8.5	29.5	3/8	NPT1/8	17	11/16
	1/4"	NDSQG 3/8 - 02	11	32.7	3/8	NPT1/4	17	11/16
	3/8"	NDSQG 3/8 - 03	12	33	3/8	NPT3/8	17	7/8
	1/2"	NDSQG 3/8 - 04	14	35.7	3/8	NPT1/2	17	1/1
1/2"	1/8"	NDSQG 1/2 - 01	8.5	31	1/2	NPT1/8	20	7/8
	1/4"	NDSQG 1/2 - 02	11	33.5	1/2	NPT1/4	20	7/8
	3/8"	NDSQG 1/2 - 03	12	34.5	1/2	NPT3/8	20	7/8
	1/2"	NDSQG 1/2 - 04	14	36.5	1/2	NPT1/2	20	1/1

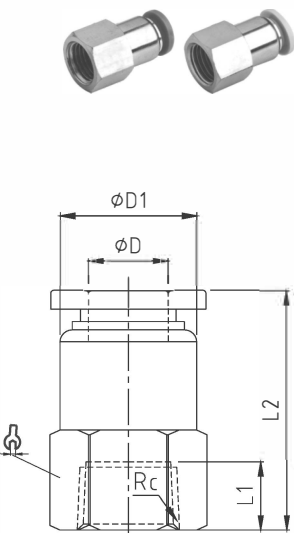

接頭、輔助元件

標準型接頭類

迷你型接頭類

柱塞類

插管式接頭類

逆止接頭類

調速接頭類

手動開關類

氣管類

消音器類